

# Optical Waveguide Theory (G)



Manfred Hammer\*

Theoretical Electrical Engineering  
Paderborn University, Paderborn, Germany

Paderborn University — Summer Semester 2025

\*Theoretical Electrical Engineering, Paderborn University Phone: +49(0)5251/60-3560  
Wärburger Straße 100, 33098 Paderborn, Germany E-mail: manfred.hammer@uni-paderborn.de

## Optical waveguide theory

- A Photonics / integrated optics; theory, motto; phenomena, introductory examples.
- B Brush up on mathematical tools.
- C Maxwell equations, different formulations, interfaces, energy and power flow.
- D Classes of simulation tasks: scattering problems, mode analysis, resonance problems.
- E Normal modes of dielectric optical waveguides, mode interference.
- F Examples for dielectric optical waveguides.
- G Waveguide discontinuities & circuits, scattering matrices, reciprocal circuits.
- H Bent optical waveguides; whispering gallery resonances; circular microresonators.
- I Coupled mode theory, perturbation theory.
- J A touch of photonic crystals; a touch of plasmonics.
- Hybrid analytical / numerical coupled mode theory.
- Oblique semi-guided waves: 2-D integrated optics.

## PICs, OICs, scattering matrices

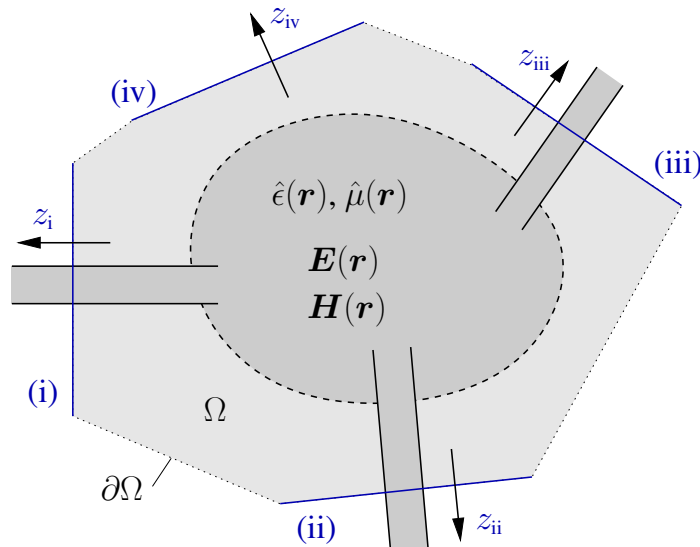

## Scattering matrices, prerequisites

- Passive, linear circuit.  $\sim \exp(i\omega t)$  (FD)
- (Computational) domain of interest  $\Omega$ , its boundary  $\partial\Omega$ .
- Connecting channels: lossless waveguides (or “half-spaces”).
- Physical ports  $p = i, ii, \dots$ : waveguide cross-section planes, local coordinates  $x_p, y_p, z_p$ ; local axis  $z_p$  oriented outwards of  $\Omega$ .
- Establish sets  $\mathcal{N}_p$  of propagating directional normal modes  $\{\psi_{p,m}^d := (\mathbf{E}_{p,m}^d, \mathbf{H}_{p,m}^d), \beta_{p,m}; d = f, b\}$  on each port  $p$ .  
(Restriction to propagating fields: a condition on port positioning / a model assumption.)
- Ports & modes are such that all mode fields vanish on all “other” port planes, and on  $\partial\Omega$  outside the ports.

Field on port plane  $p$  and “outside”:

$$\begin{pmatrix} \mathbf{E} \\ \mathbf{H} \end{pmatrix} (x_p, y_p, z_p) = \sum_{m \in \mathcal{N}_p} F_{p,m} \psi_{p,m}^f(x_p, y_p) e^{-i\beta_{p,m}z_p} + B_{p,m} \psi_{p,m}^b(x_p, y_p) e^{i\beta_{p,m}z_p}$$

## Scattering matrices

- Merge all mode indices  $\{m\}$  and port IDs  $\{p\}$  into one set of mode identifiers  $\{\nu\}$ ,  $\mathcal{N} = \cup_p \mathcal{N}_p$ .  $\sim \exp(i\omega t)$  (FD)
- Assert that  $\psi_{p,\cdot}(\mathbf{r}) = 0$  for all  $\mathbf{r} \in \partial\Omega$ ,  $\mathbf{r} \notin \text{port } p$ .
- Field on  $\partial\Omega$ : 
$$\begin{pmatrix} \mathbf{E} \\ \mathbf{H} \end{pmatrix} = \sum_{\nu \in \mathcal{N}} \{F_\nu \psi_\nu^f + B_\nu \psi_\nu^b\}.$$
 (Position arguments omitted.)
- $B_\nu$ :  $\sim$  **incident modes**, traveling towards the interior of  $\Omega$ .  
 $F_\nu$ :  $\sim$  **outgoing modes**, traveling towards the exterior of  $\Omega$ .  
 Combine into amplitude vectors  $\mathbf{B}, \mathbf{F}$ .

Linear circuit  $\longleftrightarrow$  linear dependence of  $\mathbf{F}$  on  $\mathbf{B}$ ,  
 Scattering matrix  $\mathbf{S}$  of the circuit:  $\mathbf{F} = \mathbf{S}\mathbf{B}$ ,  $\mathbf{S} = (S_{\nu\mu})$ .

- $S_{\nu\nu}$ :  $\sim (\nu, b) \rightarrow (\nu, f)$ , **reflection coefficient** for mode  $\nu$ .
- $S_{\nu\mu}$ :  $\sim (\mu, b) \rightarrow (\nu, f)$ , **transmission coefficient** for modes  $\mu, \nu$ .

◀ ◻ ▶ ◀ ≡ ▶ ↻ 🔍

7

## PICs, OICs, scattering matrices, scenarios

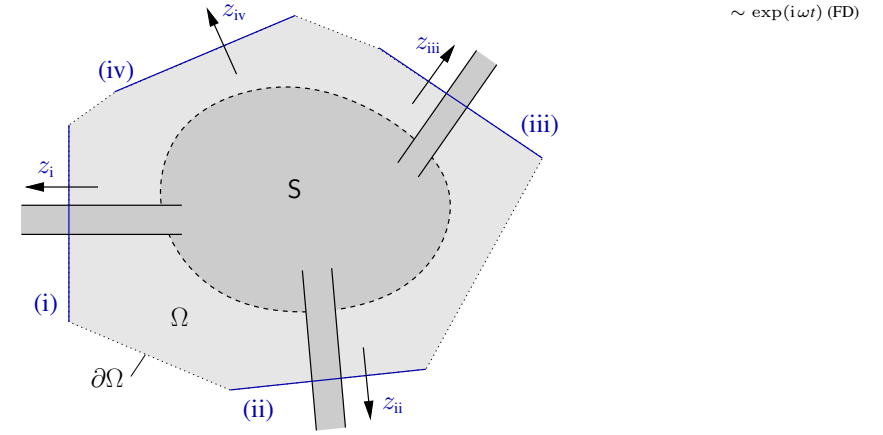

- Scenario: Full matrix  $\mathbf{S}$ , including guided and radiation modes, large  $\dim \mathbf{S} \leftrightarrow$  theoretical results.

◀ ◻ ▶ ◀ ≡ ▶ ↻ 🔍

8

## PICs, OICs, scattering matrices, scenarios

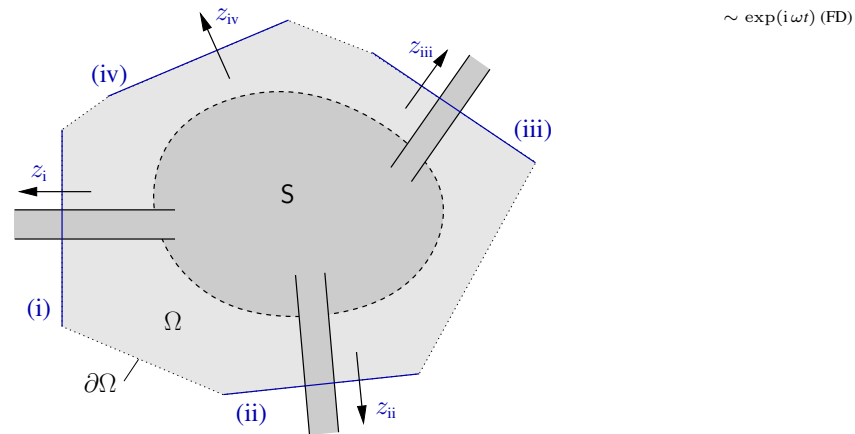

- Scenario: Restrict to a specific set of (guided) modes, or:  
 Only a small set of guided modes are relevant:  
 small  $\dim \mathbf{S} = N \times N \leftrightarrow$  an  $N$ -port circuit, a  $2N$ -pole.

( $N$ : the total number of relevant modes, not the number of ports.)

◀ ◻ ▶ ◀ ≡ ▶ ↻ 🔍

8

## Scattering matrices, port plane positions

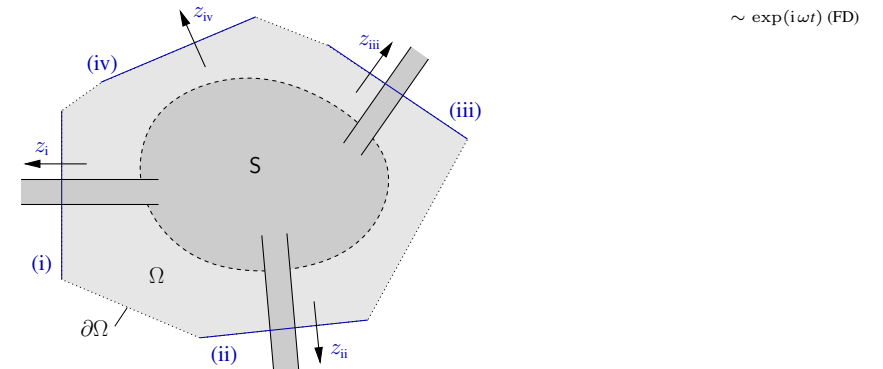

- Shift port plane of mode  $\nu$  by  $\Delta z_\nu$ :  $F_\nu \rightarrow F'_\nu = F_\nu e^{-i\beta_\nu \Delta z_\nu}$ ,  
 Shift port plane of mode  $\mu$  by  $\Delta z_\mu$ :  $B_\mu \rightarrow B'_\mu = B_\mu e^{i\beta_\mu \Delta z_\mu}$ ,  
 $\curvearrowright F'_\nu = S'_{\nu\mu} B'_\mu$ ,  $S'_{\nu\mu} = S_{\nu\mu} e^{-i(\beta_\nu \Delta z_\nu + \beta_\mu \Delta z_\mu)}$ .

(Moving port planes  $\leftrightarrow$  Phase change in reflection/transmission coefficients.)

(Moving port planes  $\leftrightarrow$  No effect on reflectances/transmittances.)

◀ ◻ ▶ ◀ ≡ ▶ ↻ 🔍

9

## Scattering matrices, port mode orthogonality

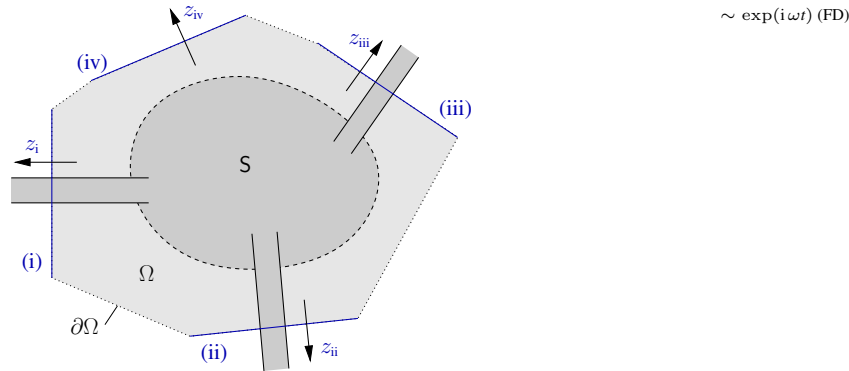

- Orthogonality relations on port plane  $p$ :

$$(\mathbf{E}_a, \mathbf{H}_a; \mathbf{E}_b, \mathbf{H}_b) = \frac{1}{4} \iint_p (E_{ax}^* H_{by} - E_{ay}^* H_{bx} + H_{ax}^* E_{by} - H_{ay}^* E_{bx}) dx_p dy_p$$

$$(\psi_{p,l}^d; \psi_{p,m}^r) = \pm \delta_{dr} \delta_{lm} P_{p,m}. \quad (\text{Things restricted to propagating modes.})$$

◀ ▶ ◀ ▶ 🔍 ↺

10

## Scattering matrices, port mode orthogonality

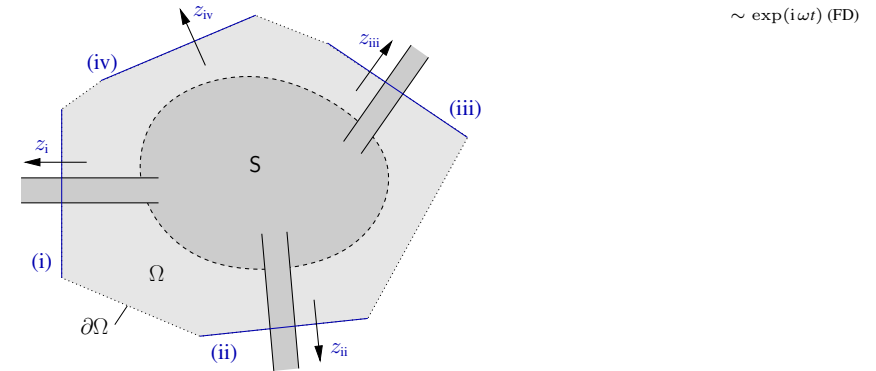

- Extend to the full boundary  $\partial\Omega$ :

$$(\mathbf{E}_a, \mathbf{H}_a; \mathbf{E}_b, \mathbf{H}_b) := \frac{1}{4} \int_{\partial\Omega} (\mathbf{E}_a^* \times \mathbf{H}_b + \mathbf{E}_b \times \mathbf{H}_a^*) \cdot d\mathbf{a}$$

$$\hookrightarrow (\psi_{p,l}^d; \psi_{q,m}^r) = \pm \delta_{dr} \delta_{pq} \delta_{lm} P_{p,m} \quad \text{or} \quad (\psi_\nu^d; \psi_\mu^r) = \pm \delta_{dr} \delta_{\nu\mu} P_\nu.$$

(Modes belonging to different ports are mutually orthogonal.)

◀ ▶ ◀ ▶ 🔍 ↺

10

## Scattering matrices, power balance



- Net power outflow across the border of the circuit:

$$P = \int_{\partial\Omega} \mathbf{S} \cdot d\mathbf{a} = (\mathbf{E}, \mathbf{H}; \mathbf{E}, \mathbf{H}) = \sum_p \sum_{m \in \mathcal{N}_p} (|F_{p,m}|^2 - |B_{p,m}|^2) P_{p,m}$$

$$= \sum_{\nu \in \mathcal{N}} (|F_\nu|^2 - |B_\nu|^2) P_\nu,$$

( $B_\xi = 0 \quad \forall \xi \neq \mu$ )

$|B_\mu|^2 P_\mu$ : incident power carried by mode  $\mu$ ,

$|F_\nu|^2 P_\nu$ : outgoing power carried by mode  $\nu$ ,  $F_\nu = S_{\nu\mu} B_\mu$ .

$$|S_{\nu\mu}|^2 \frac{P_\nu}{P_\mu} = \frac{|F_\nu|^2 P_\nu}{|B_\mu|^2 P_\mu}, \quad \mu \neq \nu: \text{ power transmittance } \mu \rightarrow \nu,$$

$$\mu = \nu: \text{ power reflectance for mode } \nu.$$

(Uniformly normalized modes,  $P_\nu = P_\mu$ : transmittances are directly given by elements of the scattering matrix.)

◀ ▶ ◀ ▶ 🔍 ↺

11

## Scattering matrices, power balance



- Net power outflow across the border of the circuit:

$$P = \int_{\partial\Omega} \mathbf{S} \cdot d\mathbf{a} = (\mathbf{E}, \mathbf{H}; \mathbf{E}, \mathbf{H}) = P_0 (\mathbf{B}^* \cdot (\mathbf{S}^\dagger \mathbf{S} - \mathbf{1}) \mathbf{B}),$$

uniform normalization,  $P_\nu = P_0$  for all  $\nu$ .

- Lossless circuit  $\iff \int_{\partial\Omega} \mathbf{S} \cdot d\mathbf{a} = 0 \iff \mathbf{S}^\dagger \mathbf{S} = \mathbf{1}$ ,  
the scattering matrix of a lossless circuit is unitary.

- Lossy circuit  $\iff \int_{\partial\Omega} \mathbf{S} \cdot d\mathbf{a} \leq 0 \iff \mathbf{B}^* \cdot \mathbf{S}^\dagger \mathbf{S} \mathbf{B} \leq \mathbf{B}^* \mathbf{B}$ ,  
 $\sum_\nu |S_{\nu\mu}|^2 \leq 1$  for all  $\mu$ . (The sum of transmittances mode  $\mu$  to all other modes  $\nu$  is less than one.)  
(Interior lossy media, or radiative losses: outgoing propagating modes not taken into account.)

◀ ▶ ◀ ▶ 🔍 ↺

12

## Scattering matrices, symmetry

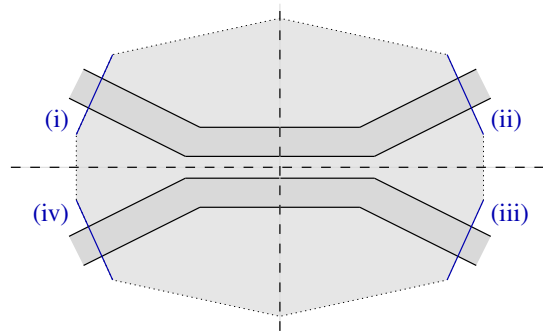

Circuit with specific spatial symmetry  
& symmetrical setting of the port planes

↪ respective symmetry in related coefficients of  $\mathbf{S}$ ,  
symmetric power transmission properties.

## Scattering matrices, reciprocity

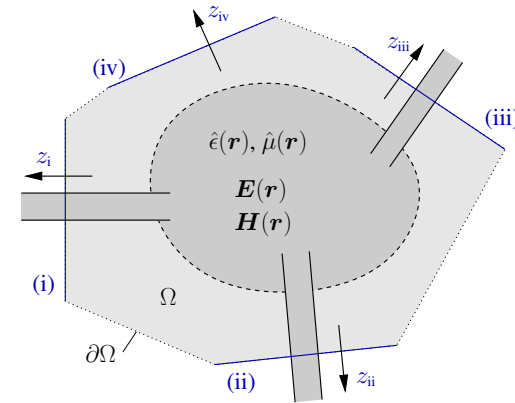

$\sim \exp(i\omega t)$  (FD)

Circuit properties  
for reversed  
wave propagation?

$S_{\nu\mu} \rightleftharpoons S_{\mu\nu}$  ?

•  $\mathbf{E}_1, \mathbf{H}_1$  and  $\mathbf{E}_2, \mathbf{H}_2$  solve  $\nabla \times \mathbf{E} = -i\omega\mu_0\hat{\mu}\mathbf{H}$ ,  $\nabla \times \mathbf{H} = i\omega\epsilon_0\hat{\epsilon}\mathbf{E}$ .

↪  $\nabla \cdot (\mathbf{E}_1 \times \mathbf{H}_2 + \mathbf{H}_1 \times \mathbf{E}_2) = 0$ , if  $\hat{\epsilon}$  and  $\hat{\mu}$  are symmetric.

(i.e. if  $\hat{\epsilon}^T = \hat{\epsilon}$ ,  $\hat{\mu}^T = \hat{\mu}$ .)

(Note: order of factors, no complex conjugates.)

## Scattering matrices, reciprocity

•  $\mathbf{E}_1, \mathbf{H}_1$  and  $\mathbf{E}_2, \mathbf{H}_2$  solve  $\nabla \times \mathbf{E} = -i\omega\mu_0\hat{\mu}\mathbf{H}$ ,  $\nabla \times \mathbf{H} = i\omega\epsilon_0\hat{\epsilon}\mathbf{E}$

↪  $\nabla \cdot (\mathbf{E}_1 \times \mathbf{H}_2 + \mathbf{H}_1 \times \mathbf{E}_2) = 0$ , if  $\hat{\epsilon}$  and  $\hat{\mu}$  are symmetric,

↪ 
$$0 = \int_{\Omega} \nabla \cdot (\mathbf{E}_1 \times \mathbf{H}_2 + \mathbf{H}_1 \times \mathbf{E}_2) d^3r = \int_{\partial\Omega} (\mathbf{E}_1 \times \mathbf{H}_2 + \mathbf{H}_1 \times \mathbf{E}_2) \cdot d\mathbf{a}.$$

• Fields on  $\partial\Omega$ :  $\begin{pmatrix} \mathbf{E} \\ \mathbf{H} \end{pmatrix}_j = \sum_{\nu \in \mathcal{N}} \{F_{j,\nu}\psi_{\nu}^f + B_{j,\nu}\psi_{\nu}^b\}$ ,  $j = 1, 2$ ,

$$[\psi_a; \psi_b] := \int_{\partial\Omega} (\mathbf{E}_a \times \mathbf{H}_b + \mathbf{H}_a \times \mathbf{E}_b) \cdot d\mathbf{a},$$

↪ 
$$0 = \sum_{\nu} \sum_{\mu} \left( F_{1,\nu}F_{2,\mu}[\psi_{\nu}^f; \psi_{\mu}^f] + F_{1,\nu}B_{2,\mu}[\psi_{\nu}^f; \psi_{\mu}^b] \right. \\ \left. + B_{1,\nu}F_{2,\mu}[\psi_{\nu}^b; \psi_{\mu}^f] + B_{1,\nu}B_{2,\mu}[\psi_{\nu}^b; \psi_{\mu}^b] \right).$$

## Scattering matrices, reciprocity

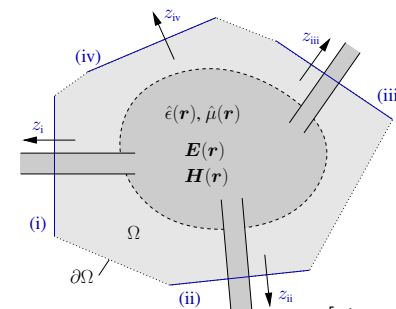

$\sim \exp(i\omega t)$  (FD)

$$[\psi_a; \psi_b] := \int_{\partial\Omega} (\mathbf{E}_a \times \mathbf{H}_b + \mathbf{H}_a \times \mathbf{E}_b) \cdot d\mathbf{a}.$$

•  $[\psi_{\nu}; \psi_{\mu}] = 0$ , if  $\nu$  and  $\mu$  relate to different ports.

• If  $\nu$  and  $\mu$  relate to the same port plane  $p$ :

$$[\psi_{\nu}^r; \psi_{\mu}^d] = \iint_p (E_{\nu x}^r H_{\mu y}^d - E_{\nu y}^r H_{\mu x}^d - H_{\nu y}^r E_{\mu x}^d + H_{\nu x}^r E_{\mu y}^d) dx_p dy_p.$$

## Scattering matrices, reciprocity

- If  $\nu$  and  $\mu$  relate to the same port plane  $p$ :

$$[\psi_\nu^r; \psi_\mu^d] = \iint_p (E_{\nu x}^r H_{\mu y}^d - E_{\nu y}^r H_{\mu x}^d - H_{\nu y}^r E_{\mu x}^d + H_{\nu x}^r E_{\mu y}^d) dx_p dy_p.$$

- Compare with the modal orthogonality relations on port plane  $p$ , for propagating modes with real transverse components:

$$(\psi_\nu^r; \psi_\mu^d) = \frac{1}{4} \iint_p (E_{\nu x}^r H_{\mu y}^d - E_{\nu y}^r H_{\mu x}^d + H_{\nu y}^r E_{\mu x}^d - H_{\nu x}^r E_{\mu y}^d) dx_p dy_p,$$

$$(\psi_\nu^f; \psi_\mu^f) = \delta_{\nu\mu} P_\nu, \quad (\psi_\nu^b; \psi_\mu^b) = -\delta_{\nu\mu} P_\nu, \quad (\psi_\nu^f; \psi_\mu^b) = (\psi_\nu^b; \psi_\mu^f) = 0.$$

- $$\begin{aligned} \psi^f &= (E_x, E_y, iE_z, H_x, H_y, iH_z)^\top \\ \psi^b &= (E_x, E_y, -iE_z, -H_x, -H_y, iH_z)^\top. \end{aligned}$$
(Real components).

$$[\psi_\nu^f; \psi_\mu^f] = [\psi_\nu^b; \psi_\mu^b] = 0, \quad [\psi_\nu^f; \psi_\mu^b] = -\delta_{\nu\mu} 4P_\nu, \quad [\psi_\nu^b; \psi_\mu^f] = \delta_{\nu\mu} 4P_\nu.$$

## Nonreciprocal devices



Isolator:  
unidirectional transmission,  
 $S_{BA} = 1, S_{AB} = 0.$

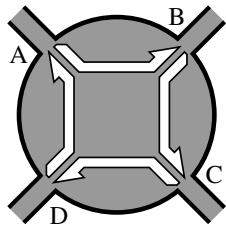

Circulator:  
transmission cycle,  
 $S_{BA} = 1, S_{CB} = 1, S_{DC} = 1, S_{AD} = 1,$   
 $S_{..} = 0$  otherwise.

Required: nonreciprocal media with  $\hat{\epsilon} \neq \hat{\epsilon}^\top$ ,  
↔ magnetooptic media, Faraday effect.

## Scattering matrices, reciprocity

$$\hookrightarrow 0 = \sum_\nu 4P_\nu (B_{1,\nu} F_{2,\nu} - F_{1,\nu} B_{2,\nu}),$$

uniform normalization  $P_\nu = P_0,$

$$\hookrightarrow 0 = \sum_\nu (B_{1,\nu} F_{2,\nu} - F_{1,\nu} B_{2,\nu}),$$

$$\hookrightarrow 0 = \mathbf{B}_1 \cdot \mathbf{F}_2 - \mathbf{F}_1 \cdot \mathbf{B}_2,$$

$$\mathbf{F}_j = \mathbf{S} \mathbf{B}_j,$$

$$\hookrightarrow 0 = \mathbf{B}_1 \cdot \mathbf{S} \mathbf{B}_2 - (\mathbf{S} \mathbf{B}_1) \cdot \mathbf{B}_2,$$

$$\hookrightarrow 0 = \mathbf{B}_1 \cdot \mathbf{S} \mathbf{B}_2 - \mathbf{B}_1 \cdot \mathbf{S}^\top \mathbf{B}_2,$$

$$\hookrightarrow 0 = \mathbf{B}_1 \cdot (\mathbf{S} - \mathbf{S}^\top) \mathbf{B}_2 \text{ for all } \mathbf{B}_1, \mathbf{B}_2.$$

$$\mathbf{S} = \mathbf{S}^\top, \quad S_{\nu\mu} = S_{\mu\nu} \text{ for all } \nu, \mu.$$

The scattering matrix of a *reciprocal circuit* is *symmetric*.

Reciprocal circuit: made of reciprocal media, with  $\hat{\epsilon} = \hat{\epsilon}^\top, \hat{\mu} = \hat{\mu}^\top.$

## Nonreciprocal devices

What about, for example,

- a long, “adiabatic” Y-junction ?
- a junction between a single mode core and a wider multimode waveguide ?



## Waveguide discontinuities

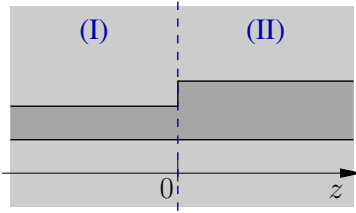

Half-infinite waveguides (I), (II), discontinuity at  $z = 0$ .

- Expand into local normal modes  $\{\psi_{s,m}^d, \beta_{s,m}\}$ ,  $m \in \mathcal{N}_s$ ,  $s = \text{I, II}$ :  
Transverse boundary conditions  $\leftrightarrow$  discrete sets.

$$\begin{pmatrix} \mathbf{E} \\ \mathbf{H} \end{pmatrix}_s(x, y, z) = \sum_{m \in \mathcal{N}_s} \left\{ f_{s,m} \psi_{s,m}^f(x, y) e^{-i\beta_{s,m}z} + b_{s,m} \psi_{s,m}^b(x, y) e^{+i\beta_{s,m}z} \right\},$$

$z < 0$ :  $s = \text{I}$ ,  $f_{\text{I},m}$  given influx,  $b_{\text{I},m}$  unknown,  
 $z > 0$ :  $s = \text{II}$ ,  $f_{\text{II},m}$  unknown,  $b_{\text{II},m}$  given influx.

$(\mathbf{E}, \mathbf{H})_{\text{I,II}}$  are solutions for  $z < 0$  and  $z > 0$ .

- Continuity of the tangential components of  $\mathbf{E}, \mathbf{H}$  at the interface  $\leftrightarrow$  formally equate expressions for  $(\mathbf{E}, \mathbf{H})_{\text{I,II}}$  at  $z = 0$ .  
(Only equality of  $E_x, E_y, H_x, H_y$  will be relevant.)
- Project on  $\psi_{s,l}^d$  to extract coefficients ...

21

## Waveguide discontinuities, scattering matrix

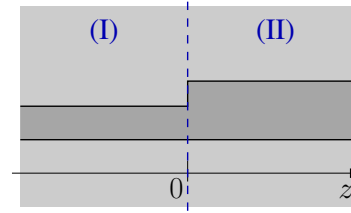

(Global coordinate  $z \neq$  former local coordinate on port I.)  
(One variant of a projection procedure.)

- $(\psi_{\text{I},l}^b; \cdot = \cdot)$ ,  $l \in \mathcal{N}_{\text{I}}$ :  
$$\sum_{m \in \mathcal{N}_{\text{I}}} [f_{\text{I},m}(\psi_{\text{I},l}^b; \psi_{\text{I},m}^f) + b_{\text{I},m}(\psi_{\text{I},l}^b; \psi_{\text{I},m}^b)] = \sum_{m \in \mathcal{N}_{\text{II}}} [f_{\text{II},m}(\psi_{\text{I},l}^b; \psi_{\text{II},m}^f) + b_{\text{II},m}(\psi_{\text{I},l}^b; \psi_{\text{II},m}^b)],$$
  - $(\psi_{\text{II},l}^f; \cdot = \cdot)$ ,  $l \in \mathcal{N}_{\text{II}}$ :  
$$\sum_{m \in \mathcal{N}_{\text{I}}} [f_{\text{I},m}(\psi_{\text{II},l}^f; \psi_{\text{I},m}^f) + b_{\text{I},m}(\psi_{\text{II},l}^f; \psi_{\text{I},m}^b)] = \sum_{m \in \mathcal{N}_{\text{II}}} [f_{\text{II},m}(\psi_{\text{II},l}^f; \psi_{\text{II},m}^f) + b_{\text{II},m}(\psi_{\text{II},l}^f; \psi_{\text{II},m}^b)],$$
- $\dots \rightsquigarrow \begin{pmatrix} \mathbf{b}_{\text{I}} \\ \mathbf{b}_{\text{II}} \end{pmatrix} = \mathbf{S} \begin{pmatrix} \mathbf{f}_{\text{I}} \\ \mathbf{f}_{\text{II}} \end{pmatrix} = \begin{pmatrix} \mathbf{S}_{\text{I,I}} & \mathbf{S}_{\text{I,II}} \\ \mathbf{S}_{\text{II,I}} & \mathbf{S}_{\text{II,II}} \end{pmatrix} \begin{pmatrix} \mathbf{f}_{\text{I}} \\ \mathbf{f}_{\text{II}} \end{pmatrix}.$

22

## Waveguide discontinuities, overlap model

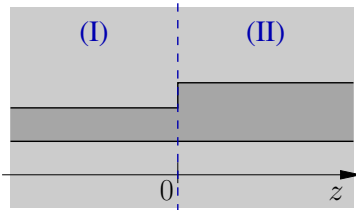

Most simplified variant:  
Unidirectional **overlap model**.

- (I): Incoming guided mode  $\psi_{\text{I}}$ , reflections & radiation neglected.  
(II): Outgoing guided modes  $\psi_{\text{II},m}$ , radiation neglected.
- $f_{\text{I}} \psi_{\text{I}} \approx \sum_m f_{\text{II},m} \psi_{\text{II},m}$  at  $z = 0$ .

$$f_{\text{II},m} = \frac{(\psi_{\text{II},m}; \psi_{\text{I}})}{(\psi_{\text{II},m}; \psi_{\text{II},m})} f_{\text{I}}, \quad \text{or} \quad f_{\text{II},m} = \frac{1}{P_{\text{II},m}} (\psi_{\text{II},m}; \psi_{\text{I}}) f_{\text{I}}.$$

(Transmission is given directly by the "overlaps"  $\leftrightarrow$  Relevance of the mode products  $(\cdot; \cdot)$ .  
(Cf. explicit expressions for overlaps of 2-D modes, involving only principal mode profile components.)

23

## A sequence of waveguide discontinuities

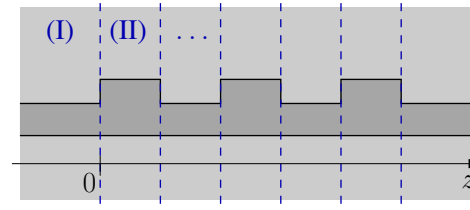

- Divide into segments.
- Establish local normal mode expansions.
- Project on local modes.

Linear system of equations for all local mode amplitudes.

$$\text{Solve } (\dots) \rightsquigarrow \begin{pmatrix} \mathbf{E} \\ \mathbf{H} \end{pmatrix}(x, y, z).$$

*Bidirectional eigenmode propagation (BEP),*  
*Eigenmode expansion method (EME),*

...

(Radiated outgoing fields: Open boundary conditions required (PMLs)  $\leftrightarrow$  Complex eigenmodes.)  
(2-D: ok. 3-D: ?)

24

## Rectangular 2-D circuits

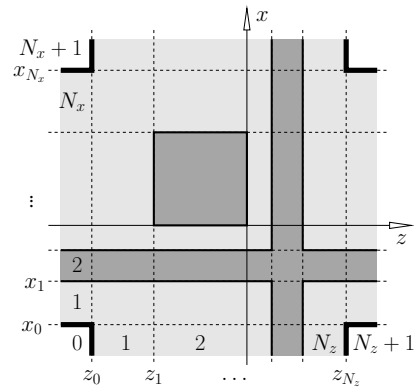

### Quadridirectional Eigenmode Propagation (QUEP)

- Divide into slices & layers.
- Establish local modes:  
Propagation along  $\pm z$ ,  
& Propagation along  $\pm x$ ,  
boundary conditions  $\phi = 0$ .
- Project at horizontal  
& vertical interfaces.

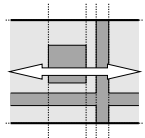

horizontal BEP,

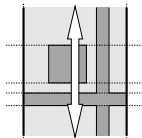

vertical BEP,

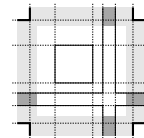

continuity at  $x_0, x_N, z_0, z_N$ .

## Upcoming

Next lectures:

- Bent optical waveguides; whispering gallery resonances; circular microresonators.
- Coupled mode theory, perturbation theory.
- A touch of photonic crystals; a touch of plasmonics.

